

A COMPARATIVE STUDY OF PERTURB AND OBSERVE AND INCREMENTAL CONDUCTANCE PV MPPT TECHNIQUES - A REVIEW

Nikita Shrivastava¹, Anula Khare², Vasant Acharya³

Gmail-nikitashrivastava1926@gmail.com¹, anulakhare03@gmail.com², vasantacharyatitc@gmail.com³

¹M.Tech Scholar, Department of Electrical and Electronics Engineering, Technocrats Institute of Technology, Bhopal, India

²Professor, Department .of Electrical & Electronics Engineering, Technocrats Institute of Technology, Bhopal, India

³Associate Professor, Department .of Electrical & Electronics Engineering, Technocrats Institute of Technology, Bhopal, India

ABSTRACT

The biggest challenge in the solar system is to extract the maximum output power from photovoltaic (PV) panels under different solar radiation and temperature conditions. This paper presents a comparative study between perturb and observe (P & O) and incremental conduction (INC) algorithms. These are the most popular algorithms for tracking solar PV panels and extracting the maximum power point (MPP) under different climate conditions. The studied PV system and the MPPT techniques have been investigated by simulation using MATLAB/Simulink. The obtained results show that the P & O performance close to MPP under constant test conditions (STC) is better than the variable conditions due to oscillation. In contrast, the performance of the INC algorithm is better than P & O in terms of speed to reach MPP, accuracy, and quality under changes in radiation and temperature conditions

Solar PV Panel, PV Characteristics,; MPPT, P&O Algorithm, INC Algorithm, STC

INTRODUCTION

Electric energy is essential in the daily life of people. The demand for electric power increases due to the increase in population and industrial development in the world. The generation of electric power increased from 17.3 trillion kilowatts in 2005 to 24.4 trillion kilowatts in 2015 and could reach 33.3 trillion kilowatts in 2030. Most of the electrical energy is generated from fossil fuels, that is, from non-renewable energy. With the increase in energy demand, economic and environmental problems have emerged, such as greenhouse gas emissions such as carbon dioxide (CO₂), Environmental contamination, and probable fossil fuel depletion. To secure the future of electricity, the globe is moving towards developing renewable energy sources [1, 2].

In light of technological development, the world has turned to renewable energy sources (RES); perhaps the most important is solar energy. Clean, sustainable energy can be trusted to form a microgrid that helps the power grid solve problems. Increasing energy demand and some environmental and economic problems resulting from fossil fuels [3,4]. Therefore, it requires quality in controlling its capabilities and the integrity of its requirements to maintain continuity of power supply [5]. Despite the benefits of PV systems, the PV system is considered to be of low efficiency due to its dependence on the power of the PV panel. The PV panel is affected by environmental factors such as radiation and temperature, which leads to energy loss and low efficiency and its impact on the electrical characteristics of voltage-current and voltage-power, thus on the connected load [6,7]. To improve the efficiency of the PV system, techniques are used for maximum power point tracking

(MPPT) in the PV panels with the converter circuit, which is done by adjusting the duty cycle (D) of the boost converter, so that the input power matches a load of the PV system. The task of MPPT is to extract the maximum possible power from the PV array under various conditions [8]. Many kinds of literature examined the use of (MPPT) techniques to improve the efficiency of the photovoltaic system, especially the techniques proposed in this paper (P&O and INC). It showed the technical efficiency of INC in terms of performance, fast-tracking time, and less fluctuation, such as [6],[7],[16],[18]. This paper presents a study of the advantages of the most common MPPT algorithms (INC) and (P&O), comparing the two methods on the MATLAB / SIMULINK platform, based on a 17 kW PV array and boost converter. INC algorithm proves to be more efficient compared to P&O in terms of fast-tracking time, low oscillation, and good performance in various weather conditions.

MPPT ALGORITHMS

Climatic conditions and accompanying changes such as temperature and radiation affect power generation in a PV array, leading to a chipping phenomenon in the generation. With an increasing temperature, the Voc voltage decreased, while solar radiation increased the ISC current of the short circuit. A single point in the PV array can operate at a maximum loading force called the Maximum Power Point (MPP). The site of this point is non-linear and affected by temperature changes and solar radiation, which leads to its deflection, so the photoelectric system should use the MPPT maximum power point tracking algorithm to ensure the efficiency High for system and continuous operation

without cutting [12,13].

Figure 5 shows the characteristics curve of open-circuit voltage and short circuit current I-V and the power curve for open-circuit voltage P-V. It references the maximum MPP power point of the PV array. MPPT algorithm can be defined as a technique used to track the maximum power point in a PV array and maintain the output power's stability under different temperature and solar radiation changes. There are many algorithms used for this purpose. Each algorithm has different characteristics and advantages in terms of simplicity, complexity, speed of proximity of MPP, vibration, electronic and computational cost [14,15]. P&O and INC algorithms are considered the most popular in use due to their excellent features, including ease of implementation, MPP proximity, and response speed [16]. The two algorithms will be explained in the section below.

PERTURB AND OBSERVE (P&O)

The P&O technique is commonly used to extract power near a PV array. The advantages of this technique are that it is easy to implement, has excellent performance, and can be used in low-cost systems. The principle of this technique's work is based on the disturbance of current or voltage in the PV array by decreasing or increasing the "On" time of the pulse period at each cycle and its effect on the output power. In addition, it involves periodic monitoring, comparison of frequencies in voltage or current, and controlling the reduction and increase of the voltage or even the current. The period can be increased or decreased depending on the formula $\Delta P/\Delta V$. If the value $\Delta P/\Delta V$ is more significant than zero, the algorithm decreases the "On" period.

On the other hand, suppose the value $\Delta P/\Delta V$ is less than zero. In that case, after several iterations, the algorithm increases the "On" period until it reaches a constant value close to the PV array's maximum power point (MPP). Hence, it requires current and voltage sensors. Figure 6 provides a flowchart of the P&O algorithm [17,18].

INCREMENTAL CONDUCTANCE ALGORITHM (INC)

The INC algorithm has been proposed to overcome some shortcomings of the (P&O) algorithm, such as steady-state error, rapid response to variable solar radiation, and convergence velocity. One advantage of this algorithm is its combination of speed and accuracy, while the P&O algorithm must choose between speed and accuracy. This is achieved by deriving the relationship $P \times V$ concerning voltage or current. MPP can be calculated using the dp/dv and $-I/v$ relationship, as shown in the following derivation

SIMULATION

The MATLAB / SIMULINK platform is used to create the simulation designs. The simulation of the proposed system is performed using the P&O algorithm and then the INC algorithm based on the parameters of Tables 1 and 2. Figure 10 shows a complete system designed in Simulink.

Table 2: Design specifications of the boost converter

Parameters	Values
Maximum power (P_{max})	17.1kW
Output Voltage (V_o)	218.5 v
Output voltage ripple (ΔV_o)	0.02 v
Switching frequency (f_s)	10kHz
Load resistance (R)	2.83 Ω
Inductance (L)	5mH
Output filter capacitance	12mf

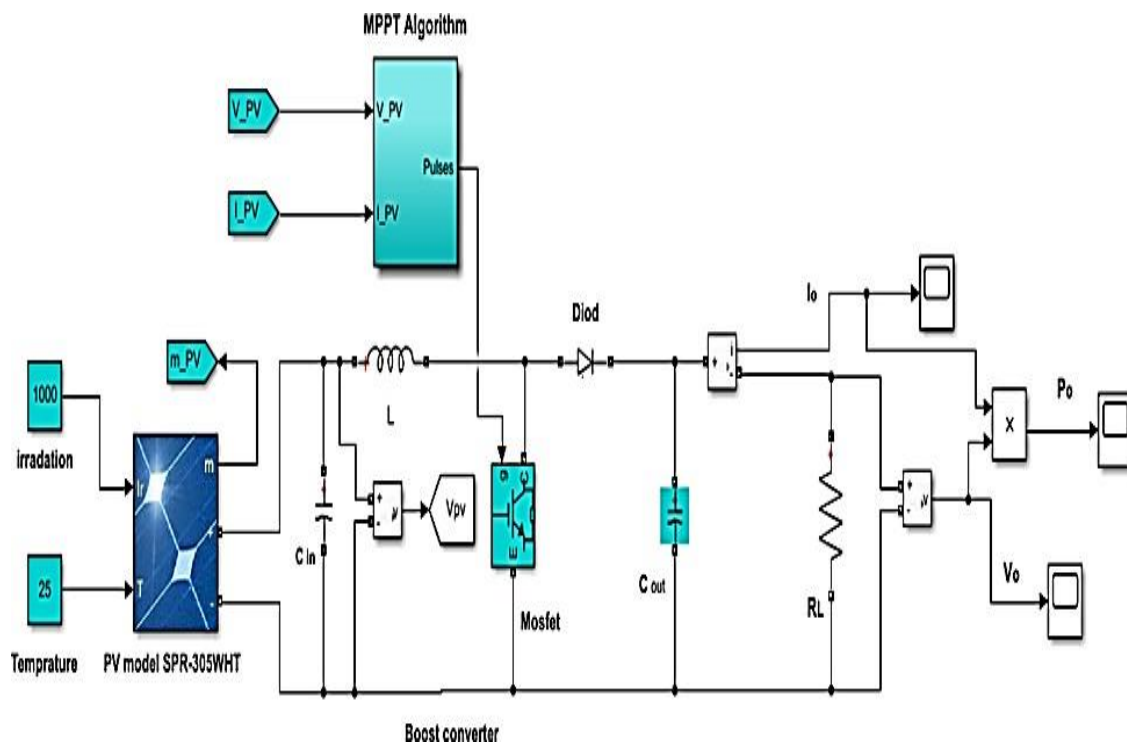

Figure 10: Complete system designed in Simulink

RESULTS AND DISCUSSION

Based on the datasheet presented in Tables 1 and 2, in which two panels were connected in series and 28 panels in parallel, the output voltage was 109.4 volts, the current was 156.24, and the output capacity was about 17kW. These results were used as a simulation for a DC power system consisting of a PV array and Boost converter, in addition to the load (R). To keep the maximum power generated by the solar panels, two technologies, MPPT P&O and INC, were used and compared. The results were implemented in two scenarios as follows:

Scenario I: Under standard test condition (STC) ($1000\text{W}/\text{m}^2$, 25°C), Figures 11 to 13 show the voltage, current, and power curves using the INC and P&O algorithm under standard conditions STC.

Simulation results show the performance of the PV system using INC and P&O algorithms STC, that is, when the temperature is constant and so is the radiation, as the P&O algorithm quickly finds MPP. Still, it oscillates at MPP due to oscillation in the duty cycle, as shown in Figure 14. In contrast, the INC algorithm finds MPP after a time delay, but there are few oscillations in the duty cycle, as in Figure 12. Optimizing the duty cycle can improve the performance of the P&O algorithm, making MPP tracking Best.

Scenario II: under partial shading conditions ($500\text{W}/\text{m}^2$, 32°C), In this case, the system is tested in three cyclic states.

The first is periodic ($t = 0$ to $t = 0.6$) the radiation is reduced to $800\text{W}/\text{m}^2$ with a constant temperature (STC) of 25°C , the second cycle irradiance ($t = 0.6$ to 1.2) which gradually decreases to $400\text{W}/\text{m}^2$ by degree. The temperature changes until reaching 20°C . At the third cycle ($t = 1.2$ to $t = 2$), the radiation level returns to rise until it reaches a maximum of $1000\text{W}/\text{m}^2$ with the temperature gradually changing to 32°C . Figures 15, 16, and 17 show the curve results for tracking the maximum power of the PV array under different conditions using the INC and P&O algorithm in addition to radiation and temperature changes.

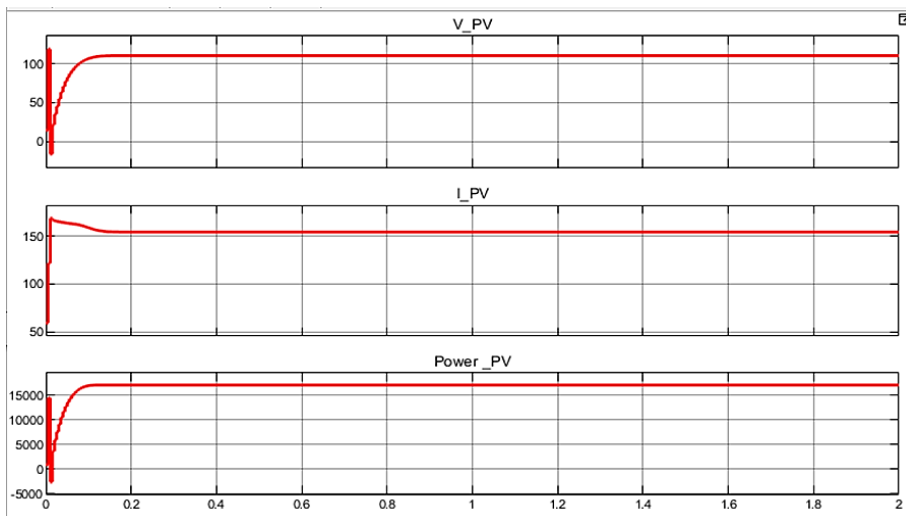

Figure 11: Voltage, current, and power output from the PV array under STC using the INC algorithm



Figure 12: The duty cycle of the INC algorithm

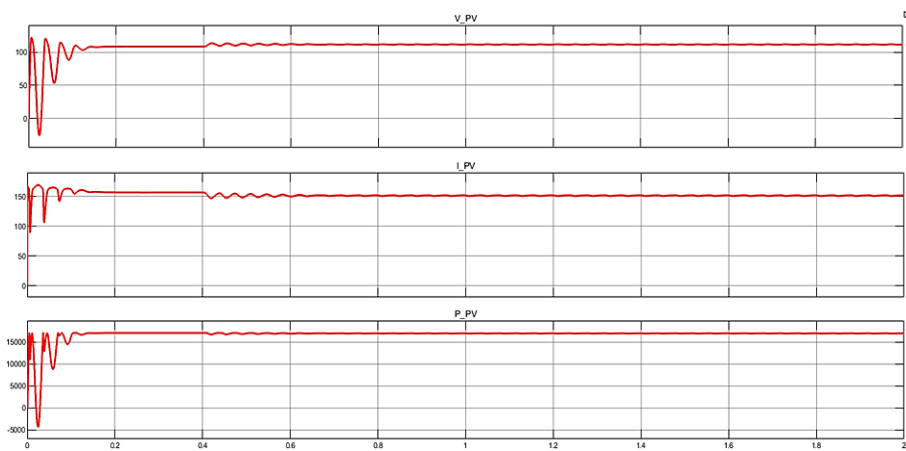

Figure 13: Voltage, current, and power output from the PV array under STC using the P&O algorithm

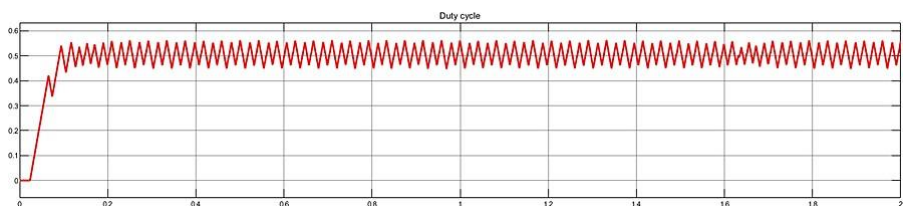

Figure 14: The duty cycle of P&O Algorithm

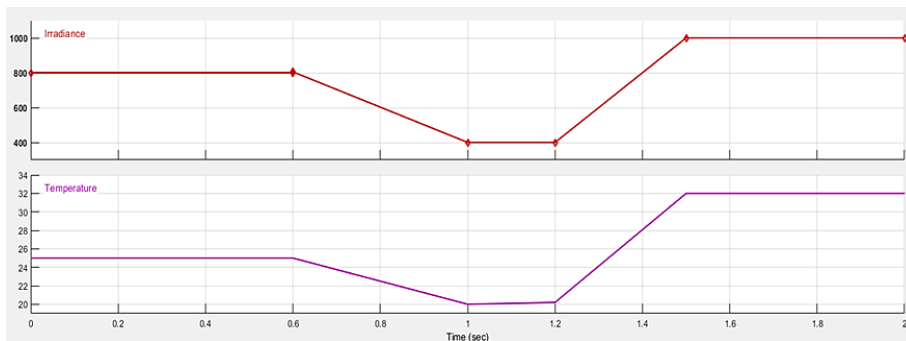

Figure 15: Radiation and temperature changes

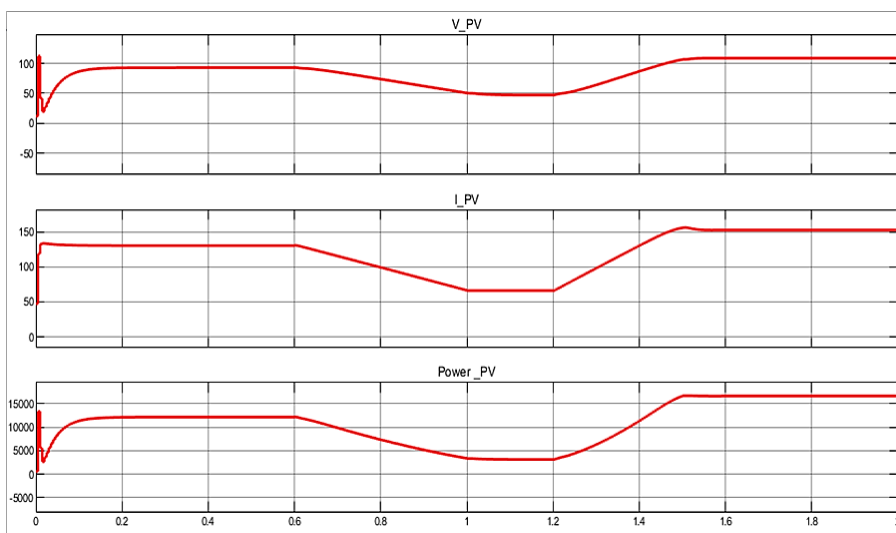

Figure 16: Voltage, current, and power output from the PV array under variable test conditions using the INC algorithm

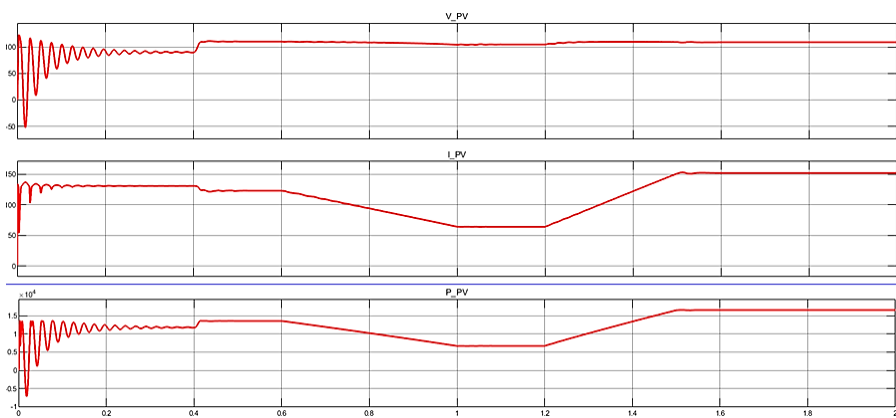

Figure 17: Voltage, current, and power output from the PV array under variable test conditions using the P&O algorithm

CONCLUSION

The work includes using MPPT technology to extract the maximum power from a 17 kW PV array under standard radiation, temperature (STC), and variable conditions. The algorithms used for this purpose are P&O and INC, and a study was conducted on the way the two algorithms work and the use of the boost converter to change the duty cycle and match The output power with the load. Based on the MATLAB /SIMULINK platform, the results were compared in the two methods. Results showed that P&O technology has the advantage of working near MPP despite slight oscillation but also works under static conditions (STC) better than variable conditions. As for INC technology, it is accurate and fast in tracking MPP compared to P&O and successfully reducing oscillation in various changing conditions, so it can be concluded that the INC algorithm works better than the P&O Algorithm.

REFERENCES

- [1] M. Kumar, 2019. Design and Simulation of Grid Connected PV System, M.Sc. thesis, IIT Univesity, Department Of Electrical Engineering.
- [2] D. Bacha: Burger, B.:Etxeberria-Otadui, I.:Martins, J., S. :Picaul. PVs in Microgrids. IEEE Industrial Electronics Magazine, 9 (2015) 33–46.
- [3] P. Ray, 2020. Microgrid : Operation, Control, Monitoring and Protection. Springer Verlag Berlin Heidelberg
- [4] W. Xiao, 2017. Photovoltaic Power System. in Photovoltaic Power System. John Wiley & Sons, USA.
- [5] K. Sasi Kottayil, 2021, Smart Microgrids book, Taylor & Francis Group, USA.
- [6] F. E. Tahiri, K. Chikh, M. Khafallah, & Saad, A. 2016. Comparative study between two Maximum PowerPoint Tracking techniques for photovoltaic system. Proceedings of 2016 International Conference on Electrical and Information Technologies, ICEIT (2016) 107–112.
- [7] K. Jain, Gupta, M., & A. Kumar Bohre, Implementation and Comparative Analysis of P&O and INC MPPT Method for PV System. India International Conference on Power Electronics, IICPE, 2018, 1–6.
- [8] A. N. M. Mohammad, , Radzi, M. A. M., Azis, N., Shafie, S., & M. A. A. M. Zainuri. An enhanced adaptive perturb and observe technique for efficient maximum power point tracking under partial shading conditions. Applied Sciences (Switzerland), 10 (2020).
- [9] A.Y. Mohammed., Modeling and Simulation of 1MW Grid Connected Photovoltaic System, M.Sc. Thesis, Department of Electrical Engineering, University of Technology-Iraq, 2017.
- [10] T. S. Kishore, , S. D. Kaushik, , & Y. Venu Madhavi. Modelling, Simulation and Analysis of PI and FL Controlled Microgrid System. Proceedings of 2019 3rd IEEE International Conference on Electrical, Computer and
- [11] A. F. Hussein, & H. A. R. Akkar. Intelligent controller Design based on wind-solar system. Eng. and Technol. J.I, 39 (2021), 326–337
- [12] C. B. N. Fapi, , Wira, P., & M. Kamta, 2019. A Fuzzy Logic MPPT Algorithm with a PI Controller for a Standalone PV System under Variable Weather and Load Conditions. Proceedings of the 2018 International Conference on Applied Smart Systems, Icass, (2018) 24–25.
- [13] M. Q. Ali, M. S. Tapou, & H. A. Dhahad. Performance evaluation of Photovoltaic Panels by a Proposed Automated System Based on Microcontrollers. Eng. and Technol. J., 39 (2021) 9–21. .
- [14] T. Vijay Muni, Priyanka, D., & S. V. N. L. Lalitha. Fast acting MPPT algorithm for soft switching interleaved boost converter for solar photovoltaic system. J. Adv. Res. Dynam. Contr. Sys., 9 Special Issue, (2018) 996–1003.
- [15] S. D. Al-Majidi, , M. F. Abbod, , & H. S. Al-Raweshidy. A novel maximum power point tracking technique based on fuzzy logic for photovoltaic systems. Int. J. Hydrogen Energy, 43 (2018) 14158–14171
- [16] S. Saravanan, , & N. Ramesh Babu. Maximum power point tracking algorithms for photovoltaic system - A review. Renewable and Sustainable Energy Reviews, 57 (2016) 192–204.
- [17] F. L. Tofoli, , D. De Castro Pereira, , & W. J. De Paula. Comparative study of maximum power point tracking techniques for photovoltaic systems. Int. J. Photoenergy, 2015 (i).
- [18] H. Mahmood, M., I. Ali, I., & A. Ahmed, O. Comparative Study of Perturb & Observe, Modified Perturb & Observe and Modified Incremental Conductance MPPT Techniques for PV Systems. Eng. and Technol. J., 38 (2020) 478–490